

MARANGONI COMPANY IN ROVERETO

Shop number: 4670 – Construction year: 2008

MAIN TECHNICAL DATA:

Boiler

Circulation	Natural	
Steam flow	15	t/h
Operating pressure	44	barg
Inlet water temperature	120	°C
Outlet steam temperature	435	°C
Outlet gas temperature	205	°C
Recovered heat	12	MW
Cleaning system	Hammers	

Heat Source

Rotary kiln		
Gas flow	13	kg/s
Gas temperature	980	°C
Dust content	200	kg/h
Heat supplied	15	MW

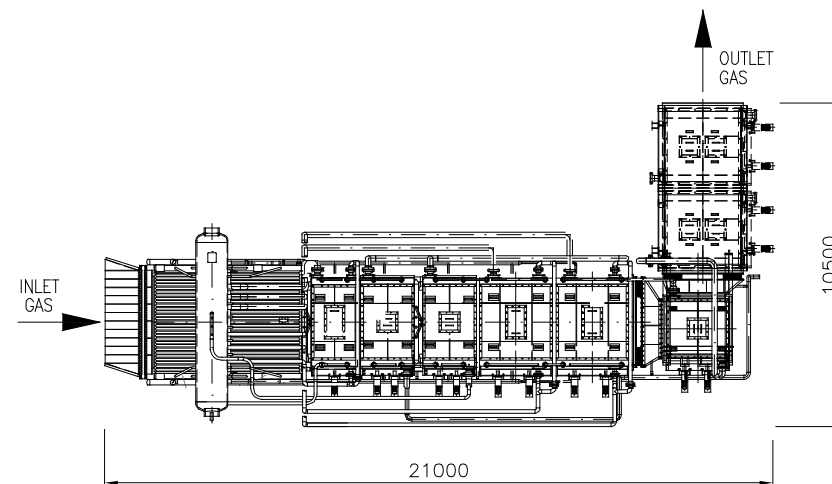
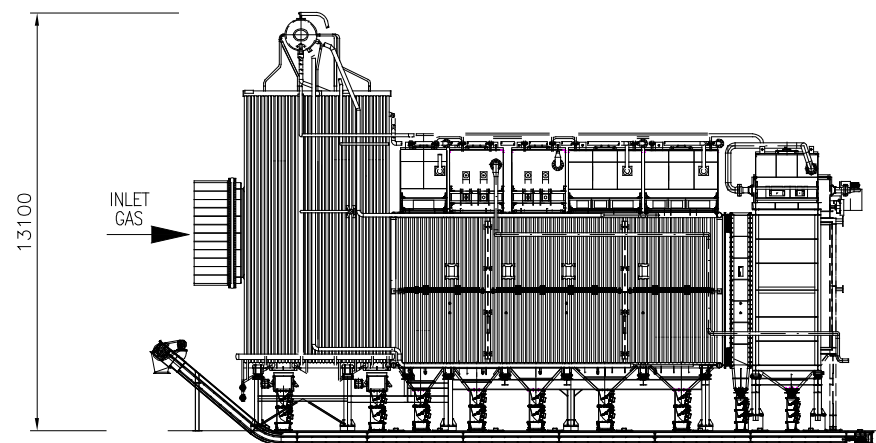
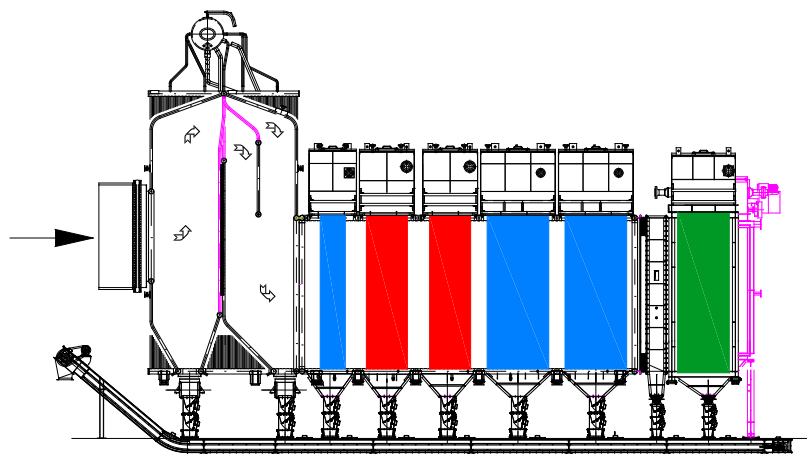

LEGENDA:



ECONOMIZER



SUPERHEATER



EVAPORIZER